

**Hollesley Parish Council  
INTERMENT FORM**

This notice must be delivered together with the certificate for disposal to Hollesley Parish Clerk, Manor Farm, Hollesley, Woodbridge, Suffolk, IP12 3NB not later than THREE CLEAR WORKING DAYS BEFORE THE PRE-ARRANGED TIME FOR THE BURIAL.

**Deceased's Details**

Full Name of Deceased:.....  
 Address: .....  
 ..... Post Code:.....  
 Age:..... Sex:..... Date of Death:.....

**Service Details**

Day and date of Burial:	Time of Burial:
Name of Minister and Address:	Denomination:
Additional services required (state any special requests):	

**Grave and Coffin Details**

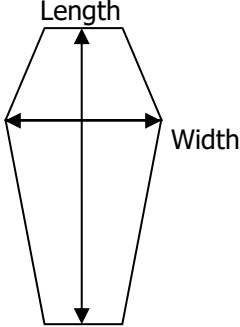
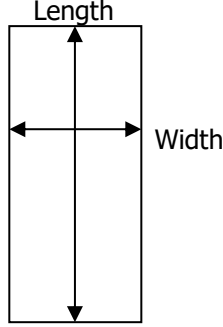
Purchased Grave		New Grave		Re <input type="checkbox"/> in <input type="checkbox"/>	
If new grave, type required: Cemetery <input type="checkbox"/>		Memorial Wall		<input type="checkbox"/>	
<i>Please complete ownership details overleaf</i>					
Grave Number:			Depth Required:		
Coffin Dimensions: Length _____ Width _____ Height _____ (from base to lid)			Casket Dimensions: Length _____ Width _____ Height _____ (from base to lid)		
					
Locking Handles? <u>Yes/No</u> (delete which doesn't apply) <b>Please provide actual maximum measurements</b>			Locking Handles? <u>Yes/No</u> (delete which doesn't apply) <b>Please provide actual maximum measurements</b>		

**Office Use Only**

	Fees	£	p
Burial Reg	Purchase		
Record Bk	Interment		
Grave Reg	Transfer		
Deed Prepared	Other:		
Grant Reg			
A/c no			
	£		

**Funeral Director**

Name:.....  
 Address: .....  
 .....  
 ..... Post Code:.....  
 Telephone No:.....

*Please ensure details on the reserve are completed*

Hollesley Parish Council  
INTERMENT FORM

**New Graves**

If the grave is to be purchased:

Full Name(s) of Purchaser(s):.....

Address: .....

..... Post Code: .....

**Note:** The person(s) named above will be registered as the grave owner(s) with the deed being made in his/her/their name(s). No memorial may be arranged and no further interment may take place without the signed consent of the grave owner(s)

**Purchased Graves, Conditions Covering Burial**

1. The Exclusive Right of Burial is granted for a period of 25 years dating from the first burial.
2. The whole of the grave space will be turfed flat and mown by Cemetery staff.
3. All memorials should be a maximum of 2 feet 6 inches (0.76 metres) in height by 2 feet 6 inches (0.76 metres) in width with a base no more than 12 inches deep (0.30 metres).
4. The grave will be maintained in accordance with the Rules and Regulations of the Hollesley New Cemetery

***NO KERBSTONES ARE ALLOWED***

**Purchased Graves**

The person applying for the burial must agree to these conditions and sign and date below:

Signed: ..... Date: .....

**Previously Purchased Graves**

The Registered Owner of the Exclusive Right of Burial must give permission for the burial by signing below. If the owner is deceased, the person arranging the funeral should complete this section.

I consent to grave number ..... being opened for the burial of the late

.....

Signed: ..... Date: .....

*Please contact the Parish Clerk for any queries regarding transferring ownership of the Exclusive Right of Burial*

**Permission to Remove Existing Memorial for the Interment**

The Registered Owner of the Exclusive Right to Erect a Memorial must give permission for the temporary removal of the Memorial by signing below. If the owner is deceased, the person arranging the funeral should complete this section.

I consent to memorial of grave number ..... being temporarily removed for the burial of the late

.....

Signed: ..... Date:.....